

# FULL PRODUCT OVERVIEW

PROVEN SOURCE • POWERFUL SOLUTIONS



**GENERAC**<sup>®</sup> | **INDUSTRIAL  
POWER**

# THE GENERAC INDUSTRIAL POWER ADVANTAGE



Generac did not become one of the largest generator manufacturers by accident. For more than six decades, Generac has driven innovation in the industry by considering generators from a unique perspective — yours. We evaluated the common problems involved in specifying, configuring, installing and maintaining generators, and created unique solutions to make Generac the best choice.

## **POWER IS ALL WE DO** – Power as an integrated system

- Generac Industrial Power only builds power systems
- We engineer and manufacture each product family as an integrated system
- Over 60 years of innovation and leadership within the power generation industry

## **CONSTANTLY UPDATING** – Code compliant

- Generac provides reliable backup power while simultaneously maintaining compliance with the ever-changing regulations, codes, and industry standards

## **NATURAL GAS TECHNOLOGY LEADER** – Reliable, cleaner, smarter

- Generac designs and manufactures advanced gaseous-powered systems that start fast and respond quickly to block loads
- Over 2 million natural gas gen-sets installed

## **ENERGY MANAGEMENT** – The flexibility to unlock value

- Industrial gas models are ready for Energy Management applications
- Products that can meet EPA certification requirements for emergency & non-emergency needs
- Only manufacturer to offer products ready for Energy Management applications from 16 kW to 750 kW

## **PROVEN POWER** – Response, power, longevity

- Generac offers a wide range of diesel-powered generator solutions from 10 kW to 3.25 MW
- Full mobile line of diesel and gaseous generators with prime ratings

## **PEACE OF MIND** – Redundancy for emergency

- Generac pioneered integrated paralleling to provide redundancy and reduce the chance of failure
- Our Modular Power Systems (MPS) eliminate the expense and space required with traditional paralleling gear

## **FACTORY-CERTIFIED TECHNICIANS** – Support you can trust

- Over 4,000 certified technicians globally
- Online, classroom, and hands-on product training
- Full support from the design stages through the life of the product

# ONE OF THE LARGEST SUPPLIERS IN THE INDUSTRY

Count on Generac Industrial Power to provide the right product to meet your demands. With our expansive product line, you'll find the reliability, consistency and flexibility to handle any power need.



## DIESEL THE TRADITIONAL CHOICE

- Diesel-fueled generators are an efficient choice for high kW applications, as well as for facilities where code requirements call for on-site fuel storage, like hospitals and 911 call centers.
- To provide the best possible diesel-fueled power solutions, Generac identifies and pre-qualifies diesel engines proven in real world applications under adverse conditions.
- We work hand-in-hand with best-in-class diesel engine manufacturers to optimize designs specifically to meet Generac requirements.



## NATURAL GAS THE SMARTEST FUEL CHOICE

- Long running times: because natural gas is supplied by a utility, refueling is not an issue.
- Fuel reliability: with natural gas, there's no on-site fuel storage or ongoing maintenance required in order to keep a clean and reliable supply of fuel.
- Fewer emissions: natural gas produces fewer emissions than diesel.



## BI-FUEL™ THE ONLY TRUE BI-FUEL SOLUTION

- Generac Bi-Fuel™ generators start on diesel fuel and add natural gas as load is applied, until the unit runs primarily on natural gas.
- Unlike practically every other bi-fuel solution on the market, Generac Bi-Fuel™ generators are fully integrated solutions. That means every fuel train component, every sensor, every actuator is specifically designed, engineered, and factory tested to work together.
- Generac Bi-Fuel™ generators have the added benefit of being EPA compliant from the factory – the only bi-fuel system on the market that can make such a claim.



Generac's paralleling power solutions provide reliable, flexible power solutions when a single generator is not appropriate for the application.

\*Mobile Gaseous Units are Tri-Fuel (Natural Gas, Liquid Propane, or Wellhead Gas)

# THE RIGHT COMPONENTS FOR YOUR APPLICATION

## GENERATOR SET ENCLOSURE OPTIONS

- Open model suited for indoor placement within a dedicated building or mechanical room
- Weather Protective Enclosure provides outdoor protection against the elements
- Sound attenuated enclosure options – up to three levels provide significantly lower sound levels and are offered in weather protective enclosures

## CODES/STANDARDS/CERTIFICATIONS\*

- UL2200 Listed: Generac was the first to introduce its complete product line in conformance with UL2200 safety standards
- EPA: Environmental Protection Agency
- NEMA: National Electrical Manufacturers Association
- CSA: Canadian Standards Association
- CARB: California Air Resources Board
- SCAQMD: South Coast Air Quality Management District (CA)
- IBC: International Building Code
- OSHPD: Office of Statewide Health Planning and Development approved with shaker table testing, SDS value = 2.5

*\*Not all codes/standards/certifications apply to all configurations*

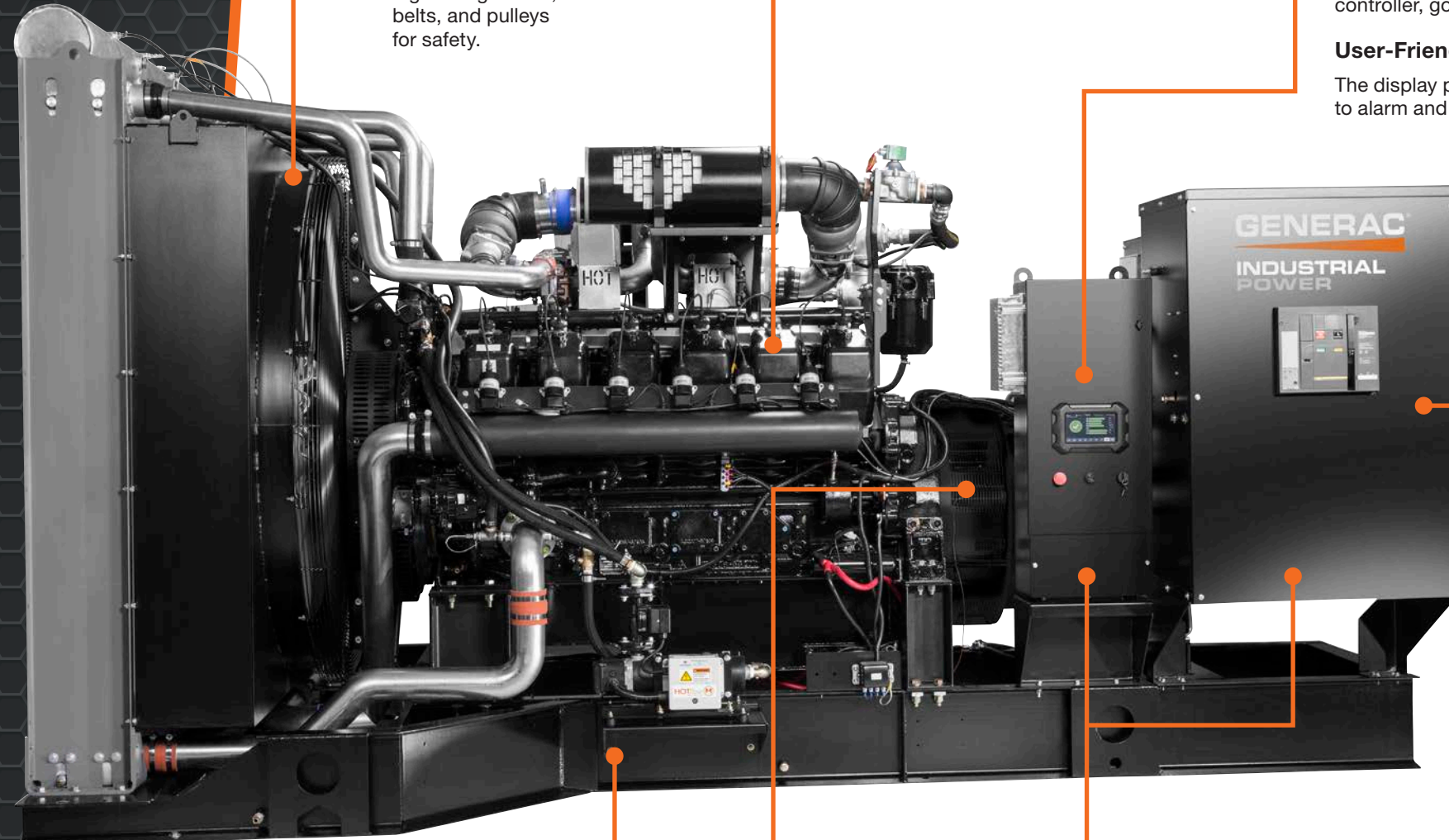

### GUARDING

Meeting UL2200 and CSA standards, Generac has Level 1 guarding for fan, belts, and pulleys for safety.

### MODERN ENGINE TECHNOLOGY

In addition to meeting EPA emission standards and sound and endurance testing, a comprehensive set of highly specialized tests including torsional analysis, transient response, maximum motor starting and structural sound test are performed.

### ADVANCED DIGITAL CONTROLS

Industrial control panels combine durable construction with seamlessly integrated components and features such as constant monitoring, built-in alarms and adjustable parameters. This helps ensure reliable generator operation.

#### Fully Integrated Design

All control functions are integrated into a single encapsulated circuit board platform: gen-set controller, governor, regulator and protection.

#### User-Friendly Interface

The display provides user-friendly access to alarm and generator operation information.

### EASIER TO WIRE

Circuit breaker positioned to provide more room for cable regrouping, and to allow cables to run straight into the breaker bays – with or without cable glanding.

### SEPARATE HIGH AND LOW VOLTAGE STUB-UP UP LOCATIONS AND TERMINAL LOCATIONS

#### Stub-Up Locations

Low voltage stub-up will be either in the middle area, between the breaker stub-up (on units with a fuel tank) or directly below the low voltage terminal strip (on units without a fuel tank). The high voltage stub-up is directly below the circuit breaker, or below the paralleling contactor for Modular Power Systems (MPS).

#### Terminal Connections

Separated to improve customer safety. Low voltage control connections are located beneath the control panel. These include two-wire start, communications, alarm relay outputs, and more. High Voltage power connections are located in the main breaker box, and used for auxiliary items like the battery charger and block heater. This terminal strip is removed if a load center is used.

### RIGID BASE FRAMES

Fully welded for strength and then finished with industrial RhinoCoat™ paint finish, our base frames are built to withstand high-torque transient conditions and eliminate vibrations.

### INDUSTRIAL ALTERNATORS

Generac industrial alternators are machine wound, machine inserted and machine varnished.

# ALTERNATORS. FUEL TANKS. BASE FRAMES. **DESIGNED FOR OPTIMIZED PERFORMANCE.**

## INDUSTRIAL ALTERNATORS

Precision winding and stack bracing ensures reliable performance with Generac's industrial alternators. Rotor spin balancing eliminates vibration, while double venting contributes to cooler operation, longer life and enhanced efficiency. All Generac Industrial alternators are built with high temperature 150°C rise Class H insulation. Maximum operating temperatures are designed not to exceed a temperature rise of 120°C. This provides an extra margin of thermal capability for standby applications with single phase and non-linear loads.

For improved motor starting capabilities and less voltage drop, Generac offers optional up-sized alternators producing more starting kVA, lower temperature rise, and better transient responses. Alternator choices include a variety of voltages, excitation options, topical anti-fungal coating and anti-condensation strip heaters.

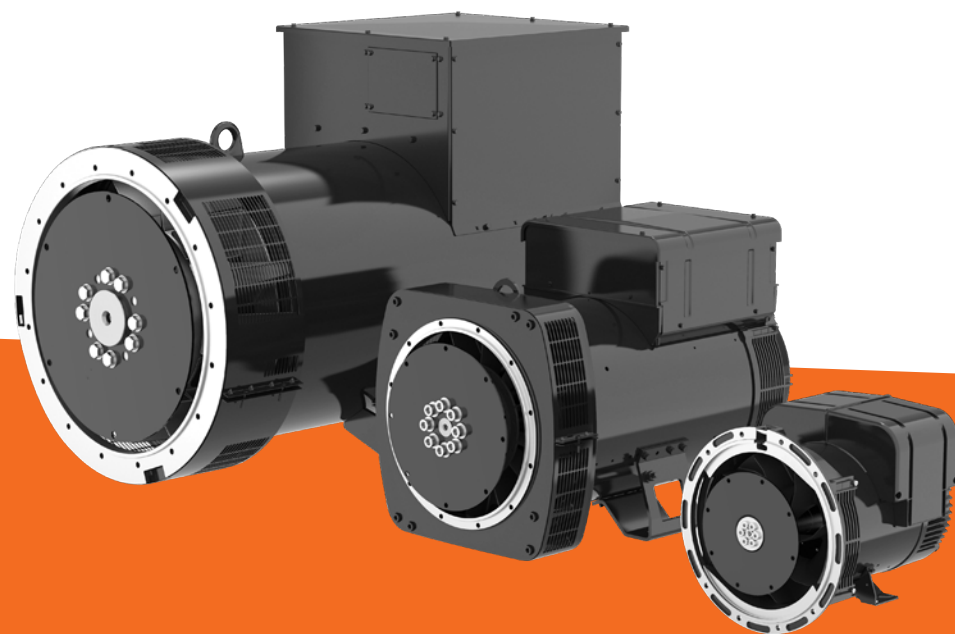

WE SPECIFY MORE THAN  
**5,000 GENERATORS**  
EVERY YEAR



## FUEL TANKS – UL-142/ULCS601 Secondary Containment

The fuel tanks for Generac gen-sets are designed and manufactured by Generac. This gives us total quality control over this critical gen-set component. Every detail is designed to protect against fuel leaks and contamination.

- Robotic weld system provides consistent welds to eliminate defects
- Factory pressure tested and double wall construction to minimize concerns of on-site fuel leaks
- Generac RhinoCoat™ powder coat paint system offers maximum protection against the elements
- Sloped tops shed water to prevent corrosion and extend tank life
- Sloped bottom ensures separation of potential water contamination
- Meets a variety of filling, venting and localized certifications
- Options include spill fill containment, vents and alarm



## BASE FRAME

Generac's heavy duty base frames assure accurate engine-alternator alignment remains intact.

- Fully welded construction resists high-torque transients while providing solid weldments for smooth, undisturbed painting surfaces
- Oil and water drain points located for easy access
- Vibration isolators contribute to smoother operation
- Power cable stub-up for easy installation
- Battery trays are welded in place prior to receiving Generac's RhinoCoat™ paint system
- Heavy duty lifting eyes

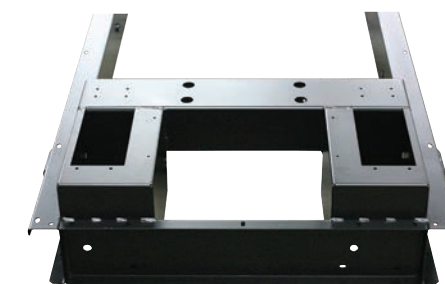

# A COMPLETE LINE OF GENERATOR ENCLOSURES

By manufacturing our own generator enclosures, Generac is able to ensure each unit combines the highest level of durability with the latest engineering advancements in noise reduction and weather resistance.

## COMPONENT DURABILITY

Corrosion resistant SermaGard® silver coated fasteners are utilized throughout the enclosure. Heavy-duty door hinges, latches, and striker plates are polished stainless steel. Internal flanges and fastener locations reduce corrosion and improve external aesthetic appearance.

- Open model suited for indoor placement within a dedicated building or mechanical room
- Large access doors have been engineered with a slip-pin hinge design for easy door removal. Slip-pin door hinges are mounted with stainless steel fasteners and polyurethane gaskets for long life durability though dissimilar metals separation
- Door jambs have closed-cell polyurethane gasketing around 100% of the door perimeter to prevent water ingress and sound egress

## LOW SOUND EMISSIONS

- Sound Attenuated Enclosures have adhesive backed acoustic silver Mylar® foam panels for maximum sound absorption, heat reflection and resistance to oil and water
- Roof acoustic foam panels are held with mechanical retention caps and pins that are capacitive discharge welded to enclosure panels

## ADDITIONAL PERFORMANCE FEATURES

- Hurricane level wind ratings with optional certifications available
- Door latches keyed for equipment security
- Full 180° door swing provides full access to generator equipment
- Heavy-duty steel or aluminum options available
- Alternate paint color options available

## TOUGH, DURABLE ENCLOSURES

Our RhinoCoat™ finish system uses a superior process that takes thermoplastic and bakes it on to the metal. This process is used on not only the enclosure, but also the base frame, fuel tank, and other sheet metal components.



### SIX-LOUVER SINGLE PIECE DIE STAMPING

This manufacturing process allows for a more accurate control of airflow while preventing water ingress



### GASKETED DOORS

Provides additional protection from weather and rodents



### STAINLESS STEEL LATCH HANDLES

- Corrosion-free, non-protruding and secure, with built-in locks
- Standard doors and positive lock clasp
- Oversized door and 3-pt tuck & turn



### NYLON WASHERS

All potential metal-to-metal contact areas are protected with a nylon washer eliminating rust points

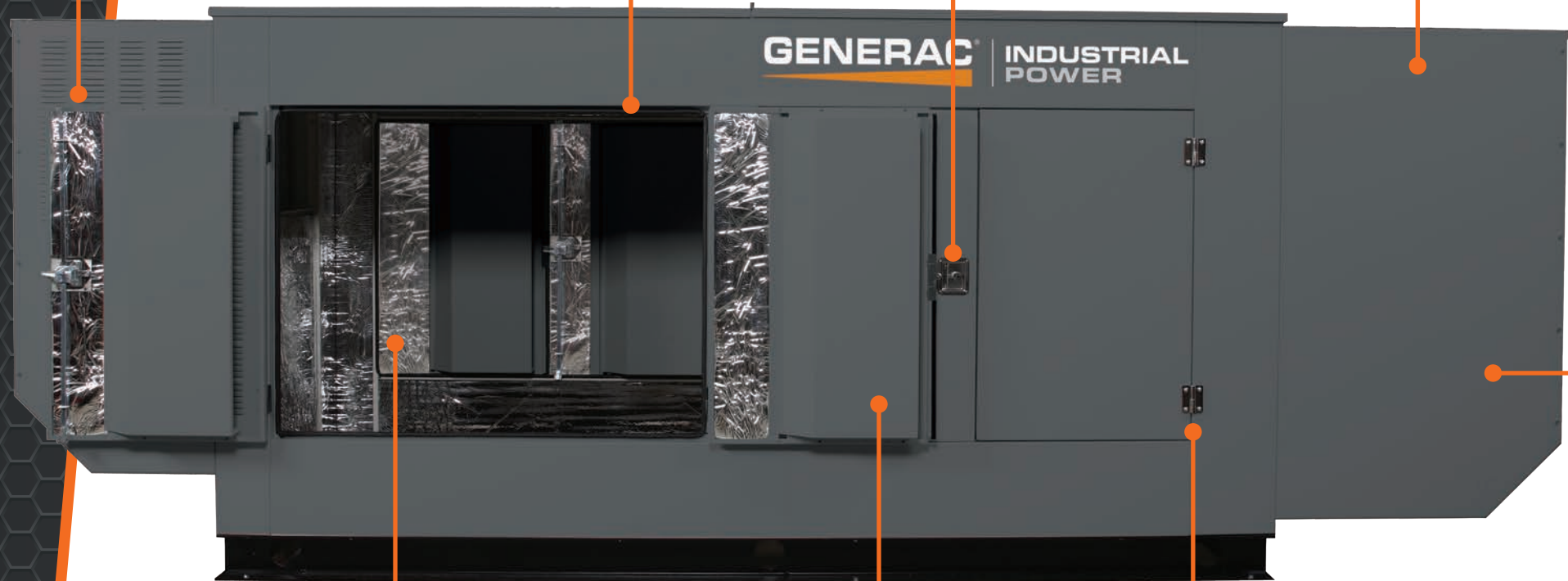

### FOAM INSULATION WITH REFLECTIVE SILVER MYLAR LAYER

- Improved sound attenuation
- Reflective surface provides added light during maintenance

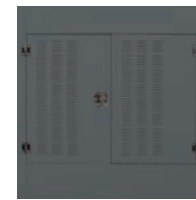

### DUAL OPENING DOORS

- Removable for extra access
- Decreases overall footprint
- Decreases weight of doors



### SLIP-PIN DOOR HINGES

Open hinge system allowing for easy removal of doors

## DISCHARGE HOOD

Improves generator reliability by:

- Mounting silencer in a functionally optimal location
- Protecting radiator core from physical damage
- Preventing circulation of hot discharge air
- Avoiding negative impacts of prevailing wind

# THE POWERMANAGER® CONTROL SYSTEM

# RELIABLE, ACCURATE, INTEGRATED CONTROLS FOR DEMANDING APPLICATIONS



**PowerManager H-100  
Generator Controller**

## POWERMANAGER® INDUSTRIAL DIGITAL CONTROLS

### H-100 Generator Controller

Monitor and control key elements of your generator system with the touch of a button or click of a mouse. Generac engineers our controls with safety and convenience as top priorities. In addition, features like constant monitoring capabilities, adjustable parameters and built-in protective alarms combine with seamlessly integrated components for the highest level of reliability.

A durable cast-aluminum housing withstands electrical interference and environmental effects. You get superior signal integrity against electrical noises and positive indication of input failures from 4 to 20 milliamp sensors.

## THE INTEGRATED CONTROLLER APPROACH

The Generac Integrated Control concept introduces one controller that's mounted on each generator consolidating all of the critical paralleling functions providing maximum system reliability. It's engineered to prevent systemic, single-point failures often seen with other approaches in the market. The Generac Integrated Control concept also reduces installation hassles and eliminates complicated and custom PLC programming - saving you time and simplifying system setup.

The Integrated Generator Control concept is the basis of the modular power system category. It includes everything you need to control paralleling - synchronizer, speed governor biasing, automatic voltage regulator biasing, communications, load sharing, metering, protective relaying, operator interface and even custom logic capabilities. Everything, that until now, required several controllers to provide.

This integrated controller platform is extremely flexible and allows you to take advantage of:

- Expandable I/O modules - analog and discrete
- Advanced communication capabilities - on-site and via web
- Supports low and medium voltage paralleling
- Custom event and alarm capabilities to site specific needs - motorized louvers, remote fuel tanks, day tanks, remote breakers, etc.
- Custom logic capabilities providing maximum application flexibility

## STAYING CONNECTED

The controller platform and associated communication module provide easy access using Modbus across serial or Ethernet. It supports connections to multiple users and devices. You can remotely monitor the MPS via a building management system or through factory provided user interface software. You can receive emails with status updates and diagnostics. Plus, communicate directly to the generator from any mobile device across the internet.



**G-Panel (PM-DCP)  
Control Panel**

### G-Panel (PM-DCP) Generator Controller

Each MPS generator includes a single, fully integrated controller and a paralleling switch. A traditional approach to paralleling three generators would typically require 14 to 20 controllers from five different manufacturers. Through the use of our control technology, the PowerManager handles the operation of individual gen-sets by utilizing one digital control per generator to control all generator functions: speed governing, voltage regulation, gen-set alarm and monitoring, synchronizing, load sharing and protection.

The paralleling switch allows the main power leads of each generator to be connected together at a common point of connection - junction box, distribution panel or simply the transfer switch generator lugs.

The consolidation of these functions significantly simplifies the system while increasing system performance and providing the ability to effectively manage up to 15 units at a time. Advantages are redundancy, flexibility and scalability while being cost competitive with large single gen-sets and significantly less than traditional paralleling systems.

Generac Industrial Power offers an expansive product lineup from 10 kW through 3.25 MW single generators and with endless power range utilizing our innovative Modular Power System (MPS) technology. Check out additional brochures at [www.generac.com/industrial](http://www.generac.com/industrial).

# POWER ZONE® CONTROLS PLATFORM



Power Zone® Pro



Power Zone® Pro Sync

## THE SMARTEST SIMPLE SOLUTION

Designed with the user in mind, the intuitive Power Zone® controllers make monitoring your generator performance and diagnostics effortless. Compatible with natural gas and diesel generators, we have made these controllers informative and easy-to-use. Power Zone® controllers quickly supply the information you need, because your time is important.



### Remote monitoring and customization control with no additional cost

Many controllers offer remote monitoring and the ability to customize the controls as part of an annual subscription service and require the purchase of additional third-party hardware. Power Zone® has built in Wi-Fi, Bluetooth, and LAN connections enabling the Power Zone® controllers to be easily integrated into complex systems requiring more advanced generator set monitoring.



### Improved diagnostics and new onboard self-help manuals

A self-help solution with built-in manuals provides critical information on demand to help reduce maintenance and repair times and improve overall performance. Additionally, modules are available to provide local and/or remote annunciation of gen-set operating status, such as low oil pressure or high coolant temperature.



### Connectivity and easy-to-use operator interface

Power Zone® controllers have built in Wi-Fi, Bluetooth, and LAN connections, enabling generator monitoring from any internet enabled device. Onboard the generator, users interface with the Power Zone's® large graphical display, making it easy to use while providing access to a wide range of data.



### Improved reporting and log history

Power Zone® archives critical engine and alternator data before and after a fault occurs, making root cause analysis easier to identify. Power Zone® collects historical data, such as generator date/run-time, operating hours and kWh produced.



### Make maintenance a proactive proposition

Power Zone® provides user access to generator status, including immediate alarm and fault notification. It prioritizes complete system fault information and translates it into clear, actionable notifications that are immediately routed, allowing proactive service scheduling to avoid downtime. Notifications can also be sent to your servicing dealer to make maintenance and repair even quicker.



### Expandable and flexible

Designed for the future, Power Zone® Pro Sync has the capability of expanding an MPS installation to an unlimited number of generators as your power requirements increase. Configurable inputs, outputs, and an integrated logic controller offer the flexibility to meet additional customer requirements.

## POWER ZONE® PRO SYNC

So how does the Power Zone® Pro Sync controller think? For starters, it can manage paralleling, automatic transfer switch, and manage the load when the gen-set is installed in a Modular Power System (MPS) configuration. No additional switchgear or paralleling controllers are required. And even in a single-node situation, the Power Zone® Pro Sync works seamlessly with Generac automatic transfer switches for complete system integration.

**Generac's Power Zone® Controllers.  
Smarter. More Intuitive.**





# FIND THE RIGHT MPS STRATEGY FOR YOUR APPLICATION

# TRANSFER SWITCHES



In a third-party switchgear approach, the generator paralleling is often controlled by load share modules and PLC equipment in the gear. Our MPS solution utilizes an integrated paralleling design concept which provides flexibility for the location of the switching and load sequencing.

## PARALLEL SWITCHING

The parallel switching can be located internally to the generator or at the switchboard.

### GENERATOR ON-BOARD

#### Generator Power Breaker (integrated on generator)

- Completely integrated
- Single source responsibility
- Minimizes switchboard complexity, footprint and cost
- Utilizes the same switching technology that is used in historical paralleling gear

### EXTERNAL

#### Power Breaker (provided at switchboard)

- Supports draw-out breaker configurations
- Utilized to create high levels of service isolation
- Allows all switching to be centralized at a common location

## LOAD SEQUENCE & INTERFACE

Load sequencing & interface can be integrated within the Generac PM-SCi, or externally provided within a custom PLC or BMS solution.

### GENERATOR ON-BOARD

#### Generac PM-SCi (factory supplied controller)

- Intended for applications that utilize transfer switches
- Consistent and easy to implement load management process
- Single source responsibility
- Reduced system complexity, startup time and cost

### EXTERNAL

#### PLC or BMS (3rd party provided)

- Allows solutions that manage loads via feeder breakers
- Allows management of complex load sequencing algorithms

Generac offers a full line of Industrial Transfer Switches to meet varying needs from light industrial applications all the way to the most demanding critical installations. Generac's flexible platforms offer a variety of switching technologies for customized solutions to meet any project's needs.

## GTS TRANSFER SWITCHES

Generac GTS transfer switches come standard with status lights that indicate switch position and source status, a programmable exerciser, independent voltage pickup and dropout adjustments, and utility phase loss conditions. Our front access test mode switch allows the entire standby system to be tested in either normal or fast test mode.

- 100 – 2,600 Amp
- Open (In-Phase) or Delayed transition option
- 2, 3, 4 Pole
- NEMA 1, 12, 3R, 4 and 4X
- UL1008 and CSA
- Two Wire Start (works with any generator)

## HTS TRANSFER SWITCHES

Generac HTS transfer switches are a microprocessor-based design for operation in conjunction with the PowerManager® H-100 or G-100 controller. HTS switches monitor utility voltage and frequency, and communicate via a RS485 communication link to the generator controllers. External LED indicate switch position and source status. An external, 3-position test switch allows testing in either normal or fast mode without opening the cabinet.

- 100 – 2,600 Amp
- Open (In-Phase) or Delayed transition option
- Contactor
- 2, 3, 4 Pole
- NEMA 1, 12, 3R, 4 and 4X
- UL1008 and CSA
- Generator Controls Communications – H-100 and G-100



## POWER SERIES SWITCHES

The Power Series Transfer Switch (PSTS) line features 3 different platforms with multiple technologies to offer the most flexible solutions up to 5,000 AMPs. All platforms are rated for 3-cycle operation with highly reliable mechanisms. Service entrance models are 100 percent rated and available with integral overcurrent protection.

**Standard:** Provides fast transfers and is an economical and easy-to-use choice for most facilities.

**Service Entrance:** Provides a disconnect that interrupts excessive voltage and allows for manually disconnecting your facility from the electrical utility. Rated for full load transfers in critical operating, emergency, legally required, and optional power systems.

**Bypass Isolation:** Designed for transfer switch applications where maintenance must be performed while maintaining continuous power to the load.

- 100 – 5,000 Amp
- Open (In-Phase), Delayed or Closed Transition
- Bypass Isolation
- Contactor, Power Frame, or Molded Case Breaker
- 2, 3, 4 Pole
- NEMA 1, 12, 3R, 4 and 4X
- UL1008/CSA/NFPA/NEC/ISO/OSHPD/IEC
- Microprocessor Based Controller
- Two Wire Start (works with any generator)
- Service Entrance and Non-Service Entrance Rated

# PACK IN THE POWER WITH THE GEMINI® – MPS TWIN PACK

When space is at a premium and reliability is critical, no other product comes close to meeting these requirements like Generac's Gemini Twin Pack. By housing two generators within a single enclosure, the Gemini Twin Pack is able to provide the same amount of power in a small footprint. Features provide built-in redundancy for superior system reliability and scalability along with load management capabilities.



## MPS SOLUTION FOR LARGE KW PROJECTS

- Parallel up to seven Gemini systems without additional switchgear
- Easily achieve N+1 and N+2 redundancy for critical loads
- Compatible with other Generac MPS nodes

## TWO GEN-SETS IN ONE ENCLOSURE

- Improved footprint density for large applications
- Inherent redundancy

## COLOR TOUCHSCREEN OPERATOR INTERFACE

For easy customer interaction



## SERVICEABILITY

- Serviceable items located to the outside
- Lift-off doors provide complete access to entire side of the generator

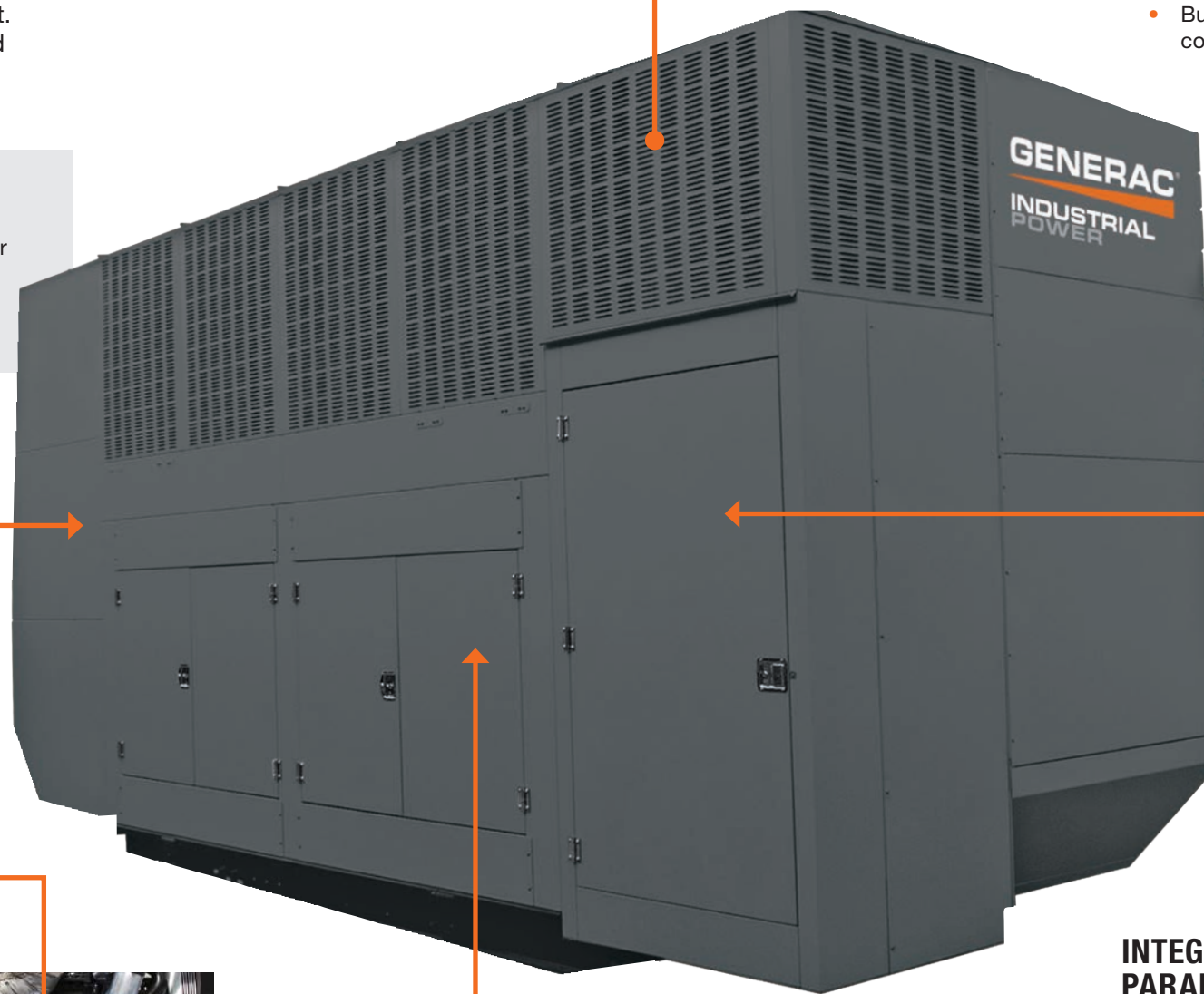
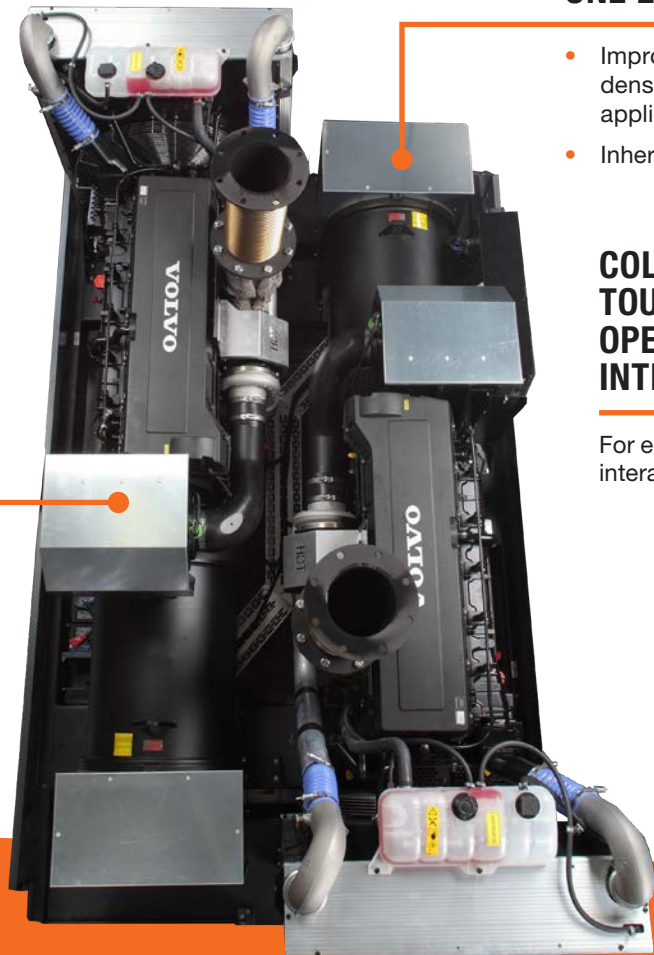

## SOUND ATTENUATED ENCLOSURE

- Air intake on side and discharge out the top for no re-circulation issues
- Built-in silencer isolated from engine compartment for enhanced reliability

## CIRCUIT BREAKERS

- Various options available
- Breakers equipped with shunt trip for redundant isolation



## INTEGRATED PARALLELING SWITCH

Premium contactor technology for enhanced cyclic duty

## INTEGRATED GEN-SET CONTROLLER

All control functions are integrated into a single encapsulated circuit board platform: gen-set controller, governor, regulator and protection

## LOAD CENTER STANDARD

Single point connection for auxiliary power

# 22-60 kW PROTECTOR™ SERIES - GASEOUS

## LIFE CONTINUES AS NORMAL DURING POWER OUTAGES

Owners of large homes and small-to-medium-size businesses rely on Protector™ Series automatic backup generators to preserve their quality of life and/or business profitability during a power outage. They are the most affordable backup power solution for larger homes and businesses, and are equipped with advanced technologies that enable 24/7/365 system monitoring and quiet operation. The smart, efficient design allows owners to continue taking advantage of their property, while keeping fuel costs low. These features combined with Generac's history of design, engineering and manufacturing excellence makes a Protector™ Series generator the best choice when investing in a backup power solution.

### PROTECTOR™ SERIES – Gaseous 25, 30, 36, 45 and 60 kW

The higher kW nodes of Generac's Protector™ Series are ideal for larger homes and small-to-medium-size businesses such as convenience stores, restaurants and offices.

- Liquid propane and natural gas fuel choices produce fewer emissions than traditional diesel engines
- True Power Technology delivers best-in-class power quality with less than 5% total harmonic distortion for clean, smooth operation of sensitive electronics and appliances

### PROTECTOR™ SERIES QUIETSOURCE (QS) – Gaseous 22, 27, 32, 36, 38 and 48 kW

Premium features are standard on the ultimate residential standby generator. For homeowners with larger residences, these units are powered by a low-speed engine for extra-quiet operation and come standard with an aluminum enclosure. QuietSource generators also include all the features of the Protector™ Series 25-60 kW.

- The low-speed, liquid cooled engine is engineered to run at only 1800 RPM for a substantially quieter generator, consuming less fuel, and giving both the engine and the alternator a longer life
- Ideal for homes requiring higher kW backup for amenities such as additional living areas, garages, and air conditioners, pools, greenhouses, guest homes, mother-in-law suites, medical needs and more



Generac generators and engines are Engineered and Built in the USA\*.

*\*Built in the USA using domestic and foreign parts*



24/7/365 Customer Support Team standing by all day, every day from our headquarters in Wisconsin to answer any questions you might have.



With smart, user-friendly controls, Generac's Evolution™ Controller features a multilingual LCD display that allows you to monitor battery status and track maintenance intervals to ensure your generator is always in top operating condition.



Quiet-Test™ Self-Test Mode runs at a lower RPM for a five or twelve minute test, making generators significantly quieter than other brands while consuming less fuel.



5-Year Limited Warranty for automatic standby generators.



Sturdy, all-weather enclosures made from corrosion-resistant aluminum modeled to withstand winds up to 150 mph, and with a fire rating (3rd-party-certified to NFPA standards) that allows for installations as close as 18" to the home and business.



The Protector Series offers compatibility with a variety of environments, with external vent and fill, a UL/CUL 142-listed, double-walled base tank, a UL/CUL 2200-listed generator, and a wide range of code-driven accessories.



Mobile Link™ Remote Monitoring connects you to your generator allowing you to access information such as the current operating status, maintenance schedule, and more using your smartphone, tablet, or PC.

# GENERAC MOBILE

## GASEOUS GENERATORS – 165 kVA-450 kVA Prime

As the global leader in gaseous fueled power generation, Generac Mobile gaseous generators offer true innovation in clean, cost-effective power. Our gaseous generators can be set to run on liquid propane, natural gas or wellhead gas - and even automatically switch over to the designated secondary fuel source if primary fuel is interrupted. With natural gas as an extremely reliable and plentiful source of fuel, new applications are constantly evolving.

### Fuel Versatility

Innovative design easily switches between liquid propane, natural gas, and wellhead gas

### Parallel-Ready Design

Offers versatility and scalable power

### Lowest Cost to Fuel

Wellhead fuel usage eliminates the need for “flare off” and provides the lowest cost to fuel power generation

### Durability

Powder-coated enclosure resists rust

### Rugged Chassis

Designed for towing to remote, off-road locations

### Telemetry Interfacing Available

For remote monitoring and location



## DIESEL GENERATORS – 8 kW-250 kVA Prime

Generac Mobile offers a comprehensive line-up of mobile diesel generators providing reliable prime power that meets your specifications or preferences. Durable sound attenuated enclosures provide quiet operation, suitable for a variety of applications and environments. Programmable controllers allow for ultimate efficiency and easy-to-read generator status screens.

### Optional SUPERSTART® Oversized Alternator

Allows for enhanced motor starting

### Voltage Regulation

For clean, steady power — suitable for sensitive electronics

### Easy Operator Interface and Serviceability

### New Extended Run Fuel System

Optional on all U.S. and Canadian FT4 diesel generators, 75 kVA and up

### Quiet Operation

Down to 66dBA

### Rugged Chassis

Designed to handle challenging terrain

### Durable

Powder-coated enclosures are durable and rust-proof

### Telemetry Interfacing Available

For remote monitoring and location

### Parallel Capable Design

Optional parallel-ready configurations allow for easy paralleling – up to 32 generators



## CANADIAN VFLEX GENERATORS – 25 kVA-330 kVA Prime

To meet the requirements of some Canadian provinces, Generac Mobile VFLEX diesel generator models offer an extra 600-volt selection for maximum fleet flexibility and convenience.

### Key Features

- Integrated transformer for ease of use
- Easy-to-switch voltage selection
- Fewer components, less parts for maintenance

### Available and Easily Switchable For Use at Any Time

- 120/240 V single phase
- 208 V three phase
- 480 V three phase
- 600 V three phase



## WE HAVE ALL YOUR MOBILE PRODUCT NEEDS

LIGHT TOWERS • HEATERS • WATER PUMPS • WATER TRAILERS • COMBO UNITS  
DUST SUPPRESSION • GENERAC PRO • GOVERNMENT & MILITARY

Explore now at [GENERACMOBILEPRODUCTS.COM](http://GENERACMOBILEPRODUCTS.COM)



**GAS ENGINES**

Model Number	kW	Engine Displacement	Open Set Footprint	Level 1 SAE Footprint	Level 2 SAE Footprint	Level 3 SAE Footprint	Open Set Weight (LBS)	Fuel Consumption 100% (scuft/hr)	
QT025A	25	2.4L	77.0 x 34.0 x 43.0	77.0 x 34.0 x 46.0	N/A	-	1,163	380	
SG035	35	4.5L	76.1 x 37.3 x 44.4	94.8 x 38.0 x 57.5	94.8 x 38.0 x 57.5	-	2,318	435	
SG040	40		76.1 x 37.3 x 44.4	94.8 x 38.0 x 57.5	94.8 x 38.0 x 57.5	-	2,221	497	
SG045	45		76.1 x 37.3 x 44.4	94.8 x 38.0 x 57.5	94.8 x 38.0 x 57.5	-	2,256	559	
SG050	50		76.1 x 37.3 x 44.4	94.8 x 38.0 x 57.5	94.8 x 38.0 x 57.5	-	2,256	621	
SG050	50	6.8L	92.9 x 40 x 75.4	129.4 x 40.5 x 55.3	111.8 x 40.5 x 67.8	-	1,929	805	
SG060	60		92.9 x 40 x 75.4	129.4 x 40.5 x 55.3	111.8 x 40.5 x 67.8	-	1,929	923	
SG070	70		92.9 x 40 x 75.4	129.4 x 40.5 x 55.3	111.8 x 40.5 x 67.8	-	1,929	1,009	
SG080	80	9.0L	92.9 x 40.0 x 48.0	129.4 x 40.5 x 56.2	111.8 x 40.5 x 68.6	-	2,371	1,247	
SG100	100		92.9 x 40.0 x 48.0	129.4 x 40.5 x 56.2	111.8 x 40.5 x 68.6	-	2,543	1,280	
SG/MG130	130		110.0 x 39.9 x 54.3	154.1 x 40.5 x 63.1	144.5 x 40.5 x 80.0	-	2,674	1,797	
SG/MG150	150		116.5 x 49.7 x 55.6	168.5 x 50.4 x 68.2	142.4 x 50.4 x 99.0	-	2,948	2,042	
SG/MG150	150	14.2L	128.0 x 53.4 x 62.3	179.9 x 54 x 69.8	154.4 x 54.0 x 93.3	207.3 x 63.7 x 128.9	5,389	2,129	
SG/MG175	175		128.0 x 53.4 x 62.3	179.9 x 54 x 69.8	154.4 x 54.0 x 93.3	207.3 x 63.7 x 128.9	5,442	2,340	
SG/MG200	200		128.0 x 53.4 x 62.3	179.9 x 54 x 69.8	154.4 x 54.0 x 93.3	207.3 x 63.7 x 128.9	5,460	2,571	
SG/MG230	230		136.0 x 57.6 x 67.9	200.2 x 57.5 x 77.8	180.6 x 57.5 x 107.3	207.3 x 63.7 x 128.9	6,031	2,775	
SG/MG250	250		136.0 x 57.6 x 67.9	200.2 x 57.5 x 77.8	180.6 x 57.5 x 107.3	207.3 x 63.7 x 128.9	6,031	2,983	
SG/MG275	275		136.0 x 57.6 x 67.9	200.2 x 57.5 x 77.8	180.6 x 57.5 x 107.3	207.3 x 63.7 x 128.9	6,587	3,161	
SG/MG300	300		136.0 x 57.6 x 67.9	200.2 x 57.5 x 77.8	180.6 x 57.5 x 107.3	207.3 x 63.7 x 128.9	6,587	3,426	
SG/MG350	350		21.9L	154.4 x 71.0 x 67.6	247.5 x 70.9 x 80.0	207.4 x 70.9 x 114.1	232.0 x 76.9 x 129.2	8,274	4,383
SG/MG400	400			154.4 x 71.0 x 67.6	247.5 x 70.9 x 80.0	207.4 x 70.9 x 114.1	232.0 x 76.9 x 129.2	8,274	4,878
SG/MG450	450			154.4 x 71.0 x 67.6	247.5 x 70.9 x 80.0	207.4 x 70.9 x 114.1	232.0 x 76.9 x 129.2	8,274	5,321
SG/MG500	500	25.8L	154.4 x 70.5 x 74.9	247.5 x 70.9 x 80.0	207.4 x 70.9 x 114.1	232.0 x 76.9 x 129.2	9,739	5,820	
SG/MG625	625	33.9L	178.3 x 82.6 x 141.9	287.9 x 96.0 x 156.5	339.9 x 151.7 x 156.5	-	14,824	6,282	
SG/MG750	750		178.3 x 82.6 x 141.9	287.9 x 96.0 x 156.5	339.9 x 151.7 x 156.5	-	16,371	7,770	

**DIESEL ENGINES**

Model Number	kW	Engine Displacement	Open Set Footprint	Level 1 Footprint	Level 2 Footprint	Open Set Weight (LBS)	Fuel Consumption 100% (GPH)
SD10	10	2.2L	76.5 x 37.4 x 42.2	112.5 x 38.0 x 49.5	94.8 x 38.0 x 62.0	1,576	1.1
SD15	15		76.5 x 37.4 x 42.2	112.5 x 38.0 x 49.5	94.8 x 38.0 x 62.0	1,576	1.4
SD20	20		76.5 x 37.4 x 42.2	112.5 x 38.0 x 49.5	94.8 x 38.0 x 62.0	1,659	1.7
SD25	25		76.5 x 37.4 x 42.2	112.5 x 38.0 x 49.5	94.8 x 38.0 x 62.0	1,659	2.1
SD30	30		76.5 x 37.4 x 42.2	112.5 x 38.0 x 49.5	94.8 x 38.0 x 62.0	1,623	2.8
SD35*	35	3.4	76.5 x 37.4 x 42.2	112.5 x 38.0 x 49.5	94.8 x 38.0 x 62.0	1,710	3.1
SD40*	40		76.5 x 37.4 x 42.2	112.5 x 38.0 x 49.5	94.8 x 38.0 x 62.0	1,710	3.5
SD50*	50		76.5 x 37.4 x 42.2	112.5 x 38.0 x 49.5	94.8 x 38.0 x 62.0	1,765	4.3
SD35	35	4.5L	92.9 x 40.0 x 49.2	129.4 x 40.5 x 56.2	111.8 x 40.5 x 68.6	2,086	3.1
SD40	40		92.9 x 40.0 x 49.2	129.4 x 40.5 x 56.2	111.8 x 40.5 x 68.6	2,086	3.4
SD50	50		92.9 x 40.0 x 49.2	129.4 x 40.5 x 56.2	111.8 x 40.5 x 68.6	2,141	4.2
SD60	60		92.9 x 40.0 x 49.2	129.4 x 40.5 x 56.2	111.8 x 40.5 x 68.6	3,326	4.8
SD80	80		92.9 x 40.0 x 49.2	129.4 x 40.5 x 56.2	111.8 x 40.5 x 68.6	3,326	6.3
SD100	100	6.7L	116.6 x 49.7 x 51.7	168.5 x 50.4 x 68.2	143.0 x 50.4 x 91.7	3,538	7.3
SD130	130		110.4 x 39.9 x 51.7	154.1 x 40.5 x 64.1	144.5 x 40.5 x 80.9	3,765	9.6
SD150	150		110.4 x 39.9 x 51.7	154.1 x 40.5 x 64.1	144.5 x 40.5 x 80.9	3,561	11.2
SD175	175		117.9 x 49.7 x 57.2	168.5 x 50.4 x 68.2	143.0 x 50.4 x 91.7	3,631	13.5
SD200	200		128.0 x 53.4 x 57.5	179.9 x 54.0 x 69.8	154.5 x 54.0 x 93.3	5,108	14.8
SD230	230	8.7L	128.0 x 53.4 x 57.5	179.9 x 54.0 x 69.8	154.5 x 54.0 x 93.3	5,108	17.0
SD250	250		128.0 x 53.4 x 57.5	179.9 x 54.0 x 69.8	154.5 x 54.0 x 93.3	5,108	18.5
SD275	275		137.5 x 57.6 x 67.8	200.2 x 57.5 x 77.8	180.7 x 57.5 x 107.3	6,461	19.6
SD/MD300	300	10.3L	137.5 x 57.6 x 67.8	200.2 x 57.5 x 77.8	180.7 x 57.5 x 107.3	7,457	22.1
SD/MD350	350		12.9L	137.5 x 57.6 x 67.8	200.2 x 57.5 x 77.8	180.6 x 57.5 x 107.3	7,330
SD/MD400	400	12.5L	137.5 x 57.6 x 67.8	200.2 x 57.5 x 77.8	180.6 x 57.5 x 107.2	7,600	27.8
SD/MD500	500	15.2L	154.4 x 71.0 x 67.3	247.5 x 70.9 x 80.0	207.4 x 70.9 x 114.1	10,580	31.2
SD/MD600	600	18.1L	154.4 x 71.0 x 67.5	247.5 x 70.9 x 80.0	207.4 x 70.9 x 114.1	10,778	41.4
SD/MD750	750	33.9L	177.7 x 82.6 x 94.0	289.0 x 99.3 x 169.3	339.9 x 150.0 x 169.3	27,822	65.2
SD/MD800	800		177.7 x 82.6 x 94.0	289.0 x 99.3 x 169.3	339.9 x 150.0 x 169.3	27,822	65.2
SD/MD900	900	37.1L	179.7 x 89.6 x 97.8	288.0 x 110.0 x 172.3	339.3 x 216.8 x 172.3	23,338	77.9
SD/MD1000	1,000		179.7 x 89.6 x 97.8	288.0 x 110.0 x 172.3	339.3 x 216.8 x 172.3	23,338	77.9
Gemini	1,000	(2) 16.0L	-	-	-	-	62.6
SD/MD1250	1,250	49.0L	215.7 x 93.1 x 108.2	330.0 x 114.0 x 199.0	404.0 x 262.0 x 199.0	27,275	94.0
SD/MD1500	1,500	65.4L	230.1 x 106.8 x 116.4	351.0 x 120.0 x 188.7	425.3 x 268.5 x 191.6	35,078	133.0
SD/MD2000	2,000		241.9 x 106.8 x 123.5	373.0 x 122.0 x 191.9	445.4 x 267.1 x 191.6	32,665	146.7

\*California only

Industrial unit charts are for reference only. Consult unit specification sheets and installation drawings for latest information

# THE RIGHT GENERATOR STARTS WITH THE RIGHT TOOLS

With more than six decades of power generation experience, Generac has built a tool set for electrical engineers and contractors to simplify and save time sizing, specifying or installing generators. The less time you spend up front, the sooner you'll have a generator on the job. No other manufacturer matches our capability to support generator design needs.

## RESOURCES

### Generac City

Commercial, Industrial, and Mission Critical Facilities rely on Generac Industrial Power every day. Explore Generac City to learn more.

### Videos

Learn more about Generac Industrial Power and see how other businesses selected Generac standby products.

### Case Studies

Read how other businesses and industries selected their Generac standby power systems, and how the investment paid off for them through a vast collection of case studies.

### PowerConnect Newsletter

Subscribe to Generac Industrial Power's newsletter to receive regular updates on new products, case studies, and trends in standby power.

### Whitepapers

There are many issues to consider when selecting a standby power system. Generac has a number of white papers that can help you understand all the considerations.

### News & Articles

Stay up-to-date on the latest news, trends, and product information related to power generation in this collection of industry articles.

## TOOLS

### Power Design Pro™

The most powerful electrical and mechanical design and sizing tool on the market. Generac's Power Design Pro is a one stop solution center for the consulting engineer.

### BIM Documents

Create intelligent designs utilizing BIM. Download Generac Industrial Power product models which have undergone quality assurance testing to meet the strict requirements of Revit.

## EDUCATION

### Professional Development Seminar Series (PDSS)

These courses are oriented towards practicing design, sales and consulting engineers involved in supplying emergency and standby power to industrial, commercial and mission critical facilities. Earn free CEU's and PDH's!

### Generac Industrial Power Engineering Symposium

The Generac Industrial Power Engineering Symposium is a 3-day event designed for the practicing engineer to walk away with a better understanding of generator sizing, application, and code compliance.

### Webinars

These informative and interactive 30-minute webinars answer the technical questions you need answers to and are a preview of the PDSS courses offered by Generac. They also cover trends in the market, new useful tools that will help you be successful, and can be accessed online or on any mobile device.

## PRODUCT INFORMATION

### Industrial Product Webpages

Explore the full line of Generac Industrial Power products including gaseous, diesel, and bi-fuel generators in a variety of configurations and outputs.

### Spec Sheets

Download any of Generac Industrial Power's product spec sheets all from one place.

### Brochures & Literature

View, save, or download brochures and literature to explore the full line of Generac Industrial Generators.

explore now at  
[WWW.GENERAC.COM/RESOURCECENTER](http://WWW.GENERAC.COM/RESOURCECENTER)

## **PROVEN SOURCE. POWERFUL SOLUTIONS.**

We are a global company with more than 4.6 million square feet of vertically integrated manufacturing and distribution capacity. We are one of North America's largest suppliers of power generation equipment with an intense focus on innovation that creates a disruptive force in the marketplace. We design and manufacture natural gas, diesel and bi-fuel generators that can work alone or be paralleled to provide you with a more robust gen-set solution. We also provide a world-class Industrial Distribution Network that stands behind you 24/7/365, as well as access to our in-house engineers and technical support.

**Our inventive Industrial Power gen-sets are standing by, ready to meet virtually any application.**

For more information or to learn more,  
visit us online or call us at:



**GeneracIndustrialPower.com**



**844-ASK-GNRC**

**GENERAC**<sup>®</sup> | **INDUSTRIAL  
POWER**

Generac Power Systems, Inc.  
S45 W29290 Hwy. 59, Waukesha WI 53189

**GeneracIndustrialPower.com**  
844-ASK-GNRC (844-275-4672)

201900786 REV 10/19

©2019 Generac Power Systems. All rights reserved.  
Specifications are subject to change without notice.